

125 LB. CAST IRON BODY SILENT WAFER CHECK VALVE

MODEL: F91-AP

PRESSURE-TEMPERATURE RATINGS

WOG: 150 psi @ 100° F

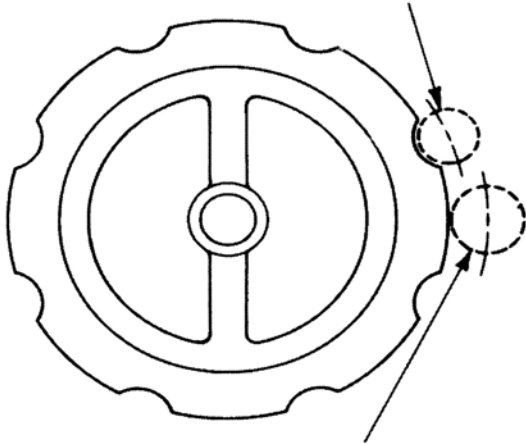

SERVICE RECOMMENDATIONS

The F91-AP is recommended for use in liquid or gas service, where temperatures & pressures are relatively low. These valves are *not* recommended for use in sewage ejector piping nor are they suggested to be installed with reciprocating compressors or pumps.

FEATURES

The spring automatically closes when the flow stops which prevents surge and water hammer. The mating surfaces of the seat & disc are handlapped. The disc is fully guided to prevent binding. Parts are field replaceable, without the need for special tools.

INSTALLATION

The F91-AP can be installed vertically, horizontally or at an angle. However, if vertical downward flow is intended, please consult factory.

CONSTRUCTION

The bodies are constructed from Cast Iron, ASTM A126, Gr. B. The standard seat and disc are made from Bronze (ASTM B62: 85-5-5-5). The spring is stainless steel, ASTM A276, type 302. The 91 series is also available with a stainless steel seat & disc instead of bronze.

Size	in.	1 1/2"	2"	2 1/2"	3"	4"	5"	6"	8"	10"	12"
	mm	38	50	65	80	100	125	150	200	250	300
Face to Face		2 3/8	2 5/8	2 7/8	3 1/8	4	4 5/8	5 9/16	6 1/2	8 1/4	11 1/4
Bolting		4 3/8 X	4 5/8 X	4 5/8 X	4 5/8 X	8 5/8 X	8 3/4 X	8 3/4 X	8 3/4 X	12 7/8 X	24 7/8 X
		5 1/4	5 3/4	6	6 1/2	7 3/4	8 1/2	9 1/2	10 3/4	13	14
WT (lb)		4	5 1/4	8	10	17	27	39	86	159	337



Purple Engineering

Australian Distributor:

Phone: +61-1300 62 40 20
 Fax: +61-8-6323 0605
 Email: Sales@Purple-Eng.com.au
 Skype: Purple.Engineering