

CLASS 1500 & 2500 CAST CARBON STEEL FLANGED & BUTTWELD "Y" STRAINERS

MODELS:

C8-1500 & C8-2500 (FLANGED)
C7-1500 & C7-2500 (BUTTWELD)

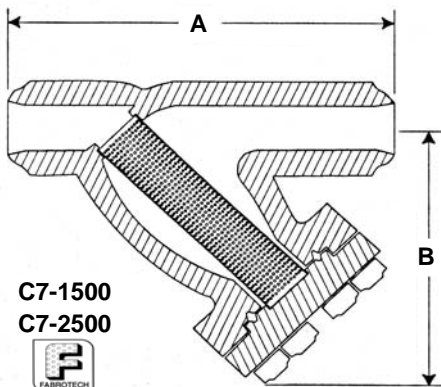
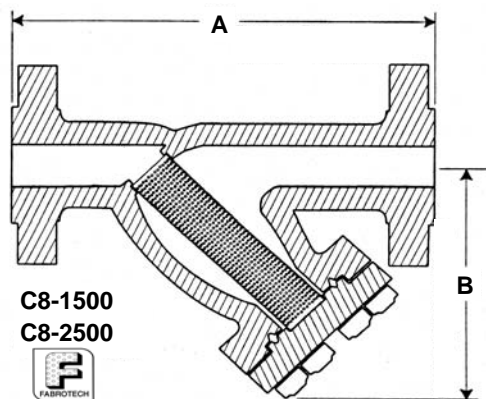

PRESSURE-TEMPERATURE RATINGS (per ANSI B16.5)		
STEAM:	C8-1500/C7-1500	1500 psi @ 838° F
	C8-2500/C7-2500	2500 psi @ 838° F
WOG:	C8-1500/C7-1500	3705 psi @ 100° F
	C8-2500/C7-2500	6170 psi @ 100° F

SERVICE RECOMMENDATIONS

These strainers are designed for long term use under very high pressure and temperature conditions. They will provide excellent protection to mechanical equipment (pumps & valves, etc.) by straining foreign particles from the pipeline.

FEATURES

All sizes have a machined body seat, which combined with the machined seat in the cover flange, creates a secure alignment for the screen. Cover flanges are furnished blind but SW or NPT connections are available. Alloy bolting and stainless steel spiral wound gaskets are standard in all sizes.

SCREENS

Fabrotech supplies heavy gauge 304 SS screens which are furnished in the following perforations:

Steam Service: To 4" - .033" perf. 5" and up - .045" perf
Liquid Service: To 4" - .062" perf. 5" and up - 1/8" perf

CONSTRUCTION

The body is cast from Carbon Steel (ASTM A216, Gr. WCB) Also available in Chrome Moly (ASTM A217 Gr. WC6 & WC9) and Carbon Moly (LCB). All flanges are drilled in accordance with ANSI B16.5. Ring Type Joint (RTJ) flanges are available. The C7-1500 is machined to match schedule 80 pipe, while the C7-2500 is machined to match double "extra-strong" pipe. We can also machine to match the bore of your pipe.

DIMENSIONS/WEIGHTS APPROX. (Apply for certified drawings)

INDIVIDUALLY HYDROSTATICALLY TESTED

SIZE	in. mm	1/2"	3/4"	1"	1 1/4"	1 1/2"	2"	2 1/2"	3"	4"	6"	8"
		15	20	25	32	40	50	65	80	100	150	200
A	C8-1500	8 1/8	9 1/16	10 3/4	12	12	13 15/16	17 1/2	17 1/2	23 1/4	32 7/16	39
	C8-2500	12 5/8	12 5/8	12 5/8	16 7/8	16 7/8	18 15/16	25 3/4	26 3/4	33 5/8	33 3/4	-
	C7-1500	7 3/8	8 3/16	9 11/16	12	12	13 15/16	17 3/8"	17 1/2	23 3/8	31	36 7/8
	C7-2500	12 5/8	12 5/8	12 5/8	16 7/8	16 7/8	17	23	23	33 3/8	36	-
B	C8-1500	4 1/4	4 3/4	5 3/4	6 3/4	6 3/4	7 1/2	10 3/4	10 3/4	15	24 1/8	26 15/16
	C8-2500	7 11/16	7 11/16	7 11/16	10 1/2	10 1/2	12 1/2	18 13/16	18 13/16	20 1/4	24 1/8	-
	C7-1500	4 1/4	4 3/4	5 3/4	6 3/4	6 3/4	7 1/2	14 3/4	14 3/4	15	20	26 15/16
	C7-2500	7 11/16	7 11/16	7 11/16	10 1/2	10 1/2	12 1/2	18 13/16	18 13/16	22 1/4	24	-
WT.	C8-1500	20	30	52	64 1/2	64 1/2	93	185	185	334	770	1200
	C8-2500	30	40	65	140	140	240	500	560	770	835	-
	C7-1500	10	17	25	29	29	44 1/2	100	100	266	621	1100
	C7-2500	30	40	65	140	140	240	500	560	740	815	-
Clean Cv (gpm)		30	35	40	40	40	70	100	150	250	550	900



Purple Engineering

Australian Distributor:

Phone: +61-1300 62 40 20
 Fax: +61-8-6323 0605
 Email: Sales@Purple-Eng.com.au
 Skype: Purple.Engineering