

600# CAST 316SS FLANGED & BUTTWELD "Y" STRAINERS

MODELS: S8-600 & S7-600

PRESSURE-TEMPERATURE RATINGS	
STEAM:	600 psi @ 1125° F
WOG:	1440 psi @ 100° F

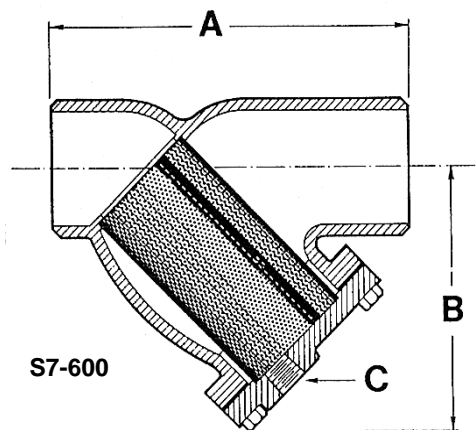
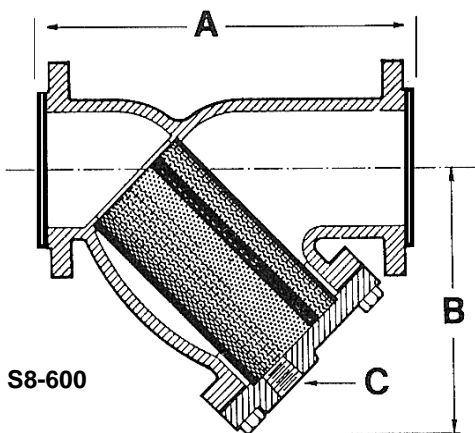

SERVICE RECOMMENDATIONS

These strainers are designed to ensure complete protection to mechanical equipment from the harmful effects of dirt, scale, etc. The S8-600 is built for a long service life and designed to withstand many different types of corrosive fluids at high pressures and temperatures.

FEATURES

All sizes feature a bolted cover machined to receive the screen. S8-600's are drilled in accordance with ANSI B16.5. Bolt holes are either spot faced or flanges are back faced. Each unit is individually hydrostatically tested. Ring Type Joints (RTJ) are available. SS spiral wound gaskets are standard. Chome moly bolting standard.

SCREENS

Fabrotech supplies heavy gauge 304 SS screens which are furnished in the following perforations as standard:

SERVICE:	1/2" - 4"	5" to 14"
Steam:	.033"	.045"
Liquid :	.062"	1/8"

Other materials, such as Monel, Hastelloy C, & Alloy-20 are available. Other perforation sizes and/or mesh lining is also available.

CONSTRUCTION

Extremely rugged & durable bodies constructed from stock in type 316 stainless steel (ASTM A351, Grade CF8M). Other alloys are available. All sizes contain generously proportioned screens with a minimum capacity of four times the corresponding pipe size. The bodies of both the S8-600 & S7-600 are designed to meet 600 lb. ANSI specifications. Model S8-600 has RF flanges and model S7-600 ends are machined to match schedule 80 pipe. Other bore schedules can be supplied. Fabrotech's models have machined seats in the body & cover which ensure accurate screen alignment.

DIMENSIONS & WEIGHTS APPROXIMATE
(Apply for certified drawings)

SIZE	in. mm	1/2"	3/4"	1"	1 1/4"	1 1/2"	2"	2 1/2"	3"	4"	5"	6"	8"	10"	12"
		15	20	25	32	40	50	65	80	100	125	150	200	250	300
A	S8-600	6 5/8	8 5/16	8 5/16	10 1/8	10 1/4	11	12	13 1/2	18	22 1/4	25 5/8	31 3/4	37 3/4	45 1/2
	S7-600	6 5/8	8 5/16	8 5/16	10 1/8	10 1/4	11	12	13 1/2	18	22 1/4	25 5/8	31 3/4	37 3/4	45 1/8
B	S8-600	3 1/2	3 3/4	3 3/4	5 1/2	5 1/2	7	8 1/4	9 1/4	12 1/2	15	20	24	28 1/2	34 1/2
	S7-600	3 1/2	3 3/4	3 3/4	5 1/2	5 1/2	7	8 1/4	9 1/4	12 1/2	15	20	24	28 1/2	34 1/2
C	NPT	3/8	1/2	1/2	1/2	1/2	1	1	1 1/4	1 1/2	2	2	2	2	2
WT (lb.)	S8-600	6	12 1/4	13	19	27	39	60	75	160	260	360	635	1090	1315
	S7-600	3	9	9	12	13	20	34	43	81	134	200	405	706	880
Clean Cv (gpm)		30	35	40	40	40	70	100	150	250	390	550	900	1500	2200

Also available in sizes 14" thru 24"



Purple Engineering

Australian Distributor:

Phone: +61-1300 62 40 20
 Fax: +61-8-6323 0605
 Email: Sales@Purple-Eng.com.au
 Skype: Purple.Engineering